

PRODUCT DATASHEET

SMART+ BT TIBEA Ceiling Tunable White

TIBEA E27 Tunable White | Indoor luminaire including LED lamp for indirect lighting with Bluetooth technology

AREAS OF APPLICATION

- General illumination
- Residential interiors
- Professional (hotels, bars, boutiques etc.)



PRODUCT BENEFITS

- Stylish and modern design
- Indirect lighting for a relaxing atmosphere
- Wireless control via app or voice control
- Easy to install and use
- Contains no mercury

PRODUCT FEATURES

- Controllable via LEDVANCE SMART+ App (with Android 6.0 and later) or Apple Home App (with iOS 10 or later)
- Adjustable color temperature via Tunable White: 2,000...6,500 K
- Dimmable
- As ceiling, pendant and mini type-version available
- Network protocol: Bluetooth
- Lifetime: up to 20,000 h



- For full functionality with control via Apple Home App connection to Apple TV (with tvOS 10 or later) or iPad (with iOS 10 or later) required

TECHNICAL DATA

Electrical data

Nominal wattage	22.00 W
Nominal voltage	220...240 V
Mains frequency	50/60 Hz

Photometrical data

Color temperature	2700...6500 K
Color rendering index Ra	>80
Light color (designation)	Tunable White
Luminous flux	1350 lm
Luminous efficacy of lamp in luminaire	61 lm/W

Dimensions & weight

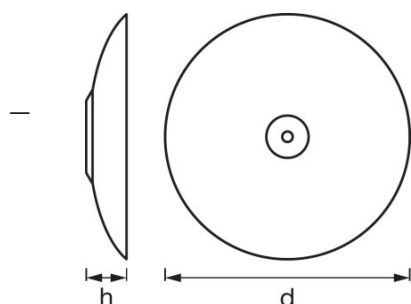

Product weight	1310.00 g
Height	51.0 mm
Diameter	500.0 mm

Colors & materials

Product color	White
Body material	Aluminum
Housing color	White

Temperatures & operating conditions

Ambient temperature range	-20...+40 °C
----------------------------------	--------------

Lifespan

Lifespan	20000 h
-----------------	---------

Capabilities

Holder designation	E27
Dimmable	Yes
Type of connection	Terminal, 2-Pole (L, N)
Compatible smart home technology	Bluetooth

Certificates & standards

Standards	CE
Protection class	II
Type of protection	IP20
Energy clas. of compatible lamps	A++/A+/A/B/C/D/E

EQUIPMENT / ACCESSORIES

- For control via LEDVANCE SMART + App Android smartphone (with Android 6.0 and later) required
- For control via Apple Home App iPhone (with iOS 10 or later), iPad (with iOS 10 or later) , Apple TV (with tvOS 10 or later) or Apple Watch (with watchOS 2 or later) required

LOGISTICAL DATA

Product code	Packaging unit (Pieces/Unit)	Dimensions (length x width x height)	Gross weight	Volume
4058075345409	Folding carton box 1	529 mm x 664 mm x 79 mm	2146.00 g	27.75 dm ³
4058075345416	Shipping carton box 2	750 mm x 610 mm x 172 mm	5357.00 g	78.69 dm ³

The mentioned product code describes the smallest quantity unit which can be ordered. One shipping unit can contain one or more single products. When placing an order, for the quantity please enter single or multiples of a shipping unit.

DISCLAIMER

Subject to change without notice. Errors and omission excepted. Always make sure to use the most recent release.